

# *The recovery of chlorine from hydrogen chloride*

## *Part 1: new method using a molten salt as the electrolyte*

S. YOSHIKAWA, Z. TAKEHARA, Y. ITO and K. OKA

*Department of Industrial Chemistry, Faculty of Engineering, Kyoto University, Yoshida, Kyoto, Japan*

Received 27 April 1971

A new method of recovering chlorine from by-product hydrogen chloride is proposed and developed. Hydrogen chloride gas is led through a carbon pipe to a gas diffusion-type porous carbon cathode, which is immersed in a molten salt of lithium chloride (58 mol%)–potassium chloride (42 mol%) at 400°C. A graphite anode is immersed in the same electrolyte. By the direct electrolysis of gaseous hydrogen chloride, hydrogen is obtained from the cathode and chlorine is obtained from the anode. Bench scale tests were also carried out.

The current capacity of the cell is 20 A. The cell voltage is 4.9 V at 20 A (500°C, electrode distance 3.8 cm) and in this case, more than 65% of it is the ohmic loss. Current efficiency is more than 90%. It can be concluded that this method is very promising.

### Introduction

The effective use of chlorine is becoming an important problem in the field of organic chemical industry. The recovery of chlorine from by-product hydrogen chloride is a particularly interesting subject in this field.

From this standpoint, some methods have been proposed, such as the Deacon method [1], Uhde cell [2], de Nora cell [3], Westvaco method [4], Schroeder method [5], Teske method [6], and Kyoto University method [7]. The Deacon method is now becoming an important technique; the Kel-Chlor method [8], which is newly developed, is also very interesting. Because of their easy operations and the purity of chlorine gas obtained electrolytic methods also seem advantageous. However, the latter all use aqueous solution as an electrolyte, and have many problems e.g. corrosion of the anode due to a side reaction, corrosion of the cell due to an humidity of a gas, large overvoltage, small

limiting current, and they should be improved in the future. In the case of the Kel-Chlor method, the purity of the chlorine gas may be a big problem.

We propose a new method, in which such difficulties can be greatly minimized. A brief explanation of it is as follows. Hydrogen chloride gas is led through a carbon pipe to a gas diffusion-type porous carbon cathode, which is immersed in a molten salt of lithium chloride (58 mol%)–potassium chloride (42 mol%) at 400°C. The graphite anode is immersed in the same electrolyte. Fig. 1 shows an experimental cell. The model of this carbon cathode is shown in Fig. 2. In this case, the anode reaction is,

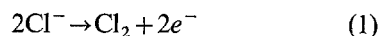

and the cathode reaction is

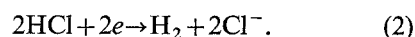

Chlorine gas is obtained from the anode and hydrogen gas from the cathode, according to the

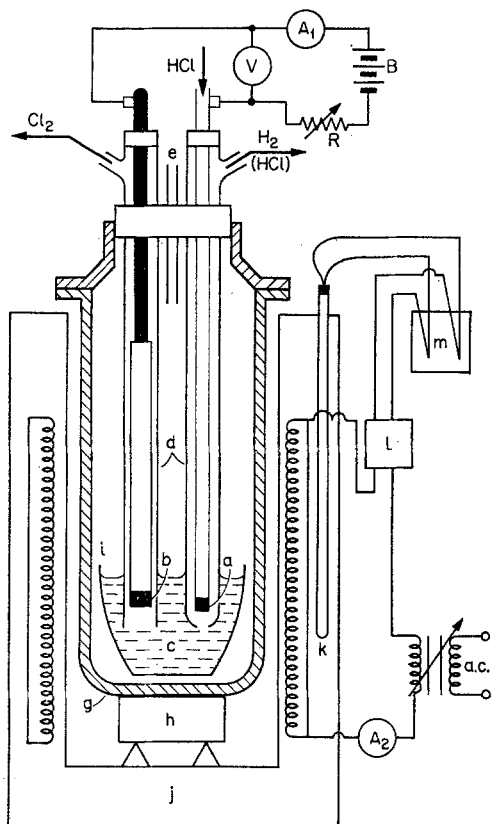

Fig. 1. Experimental cell. a: porous carbon cathode; b: graphite anode; c: electrolyte; d: pyrex holder; e: exhaust pipe; f: pyrex cap; g: pyrex container; h: spacer; i: pyrex cell; j: electric furnace; k: thermocouple; l: temperature controller; m: cold point of thermocouple; V: voltmeter; A<sub>1</sub>: ammeter; B: batteries; R: resistance; A<sub>2</sub>: a.c. ammeter.

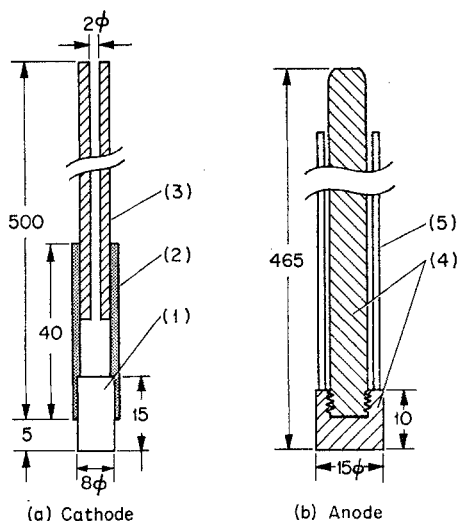
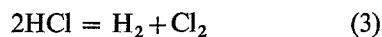

Fig. 2. Cathode and anode. 1: porous carbon; 2: carbon joint; 3: carbon pipe; 4: graphite; 5: protector.

following overall reaction,



### Thermodynamic considerations

The theoretical standard decomposition voltage of the hydrogen chloride is calculated from the standard free energy change of the reaction (3) at several temperatures and summarized in Table 1. The theoretical decomposition voltage of hydrochloric acid is also shown in Table 1 for comparison.

Table 1. Theoretical decomposition voltage

Temperature (°C)	Theoretical decomposition voltage (V) $\text{HCl}(g) = 1/2\text{H}_2(g) + 1/2\text{Cl}_2(g)$
25	0.98
100	0.99
250	1.00
500	1.03
750	1.05
1000	1.08

Concentration of hydrochloric acid (N)	Theoretical decomposition voltage (25°C) (V) $\text{HCl}(aq) = 1/2\text{H}_2(g) + 1/2\text{Cl}_2(g)$
0.1	1.48
1.0	1.36
5.0	1.29

Hydrogen chloride hardly dissolves in the molten salt system; that is, energy loss due to the solvation of the hydrogen chloride gas is negligible and that is why such large voltage differences exist. Evidently it is more advantageous to use the molten salt as an electrolyte, from the thermodynamic viewpoint.

### Practical features of this method

Electrolysis is carried out in the apparatus shown in Fig. 1. Electrolytic current-voltage characteristics are shown in Fig. 3.

Current efficiencies of chlorine evolution and hydrogen evolution are both about 100%. Conversion efficiency of the hydrogen chloride to

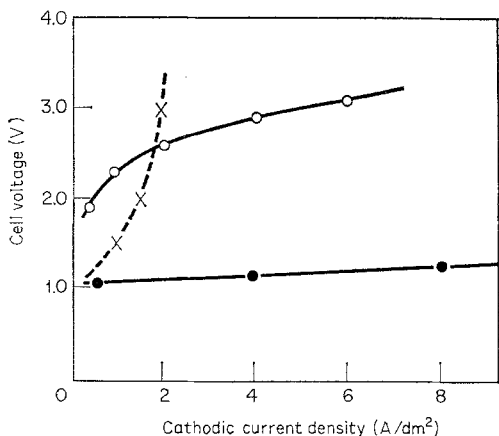

Fig. 3. Current-voltage characteristics. ●: Porous carbon cathode (under HCl supply); ○: porous carbon cathode (under Ar supply); ×: platinum plate cathode (under HCl supply).

hydrogen gas is shown in Table 2, which is cal-

Table 2. Conversion efficiency of hydrogen chloride

Current density (A/dm <sup>2</sup> )	HCl supply rate (cc/min)	Hydrogen evolution rate	Conversion efficiency (%)
10	100	3.65 cc/5 min	1.5
100	100	5.80 cc/min	11.6
200	100	12.00 cc/min	24.0

culated by dividing the decomposed amount of hydrogen chloride by the amount of that supplied to the cell during the electrolysis. The voltage balance of this cell is shown in Fig. 4. From these above-mentioned data, this method seems very promising.

### Other molten salts as electrolytes

Are there any other electrolytes which dissolve much more hydrogen chloride, are more catalytic for this electrolysis, melt at lower temperatures, and are cheaper compared with the LiCl-KCl molten salt mixture mentioned above? Some electrolytes, such as KCl-ZnCl<sub>2</sub>, NaCl-KCl-ZnCl<sub>2</sub>, AlCl<sub>3</sub>-NaCl, CaCl<sub>2</sub>-NaCl, CuCl<sub>2</sub>-KCl, and also some organic solvents are examined below.

The results obtained are as follows. Organic solvents and electrolytes containing metals which can change their valencies easily, for example,

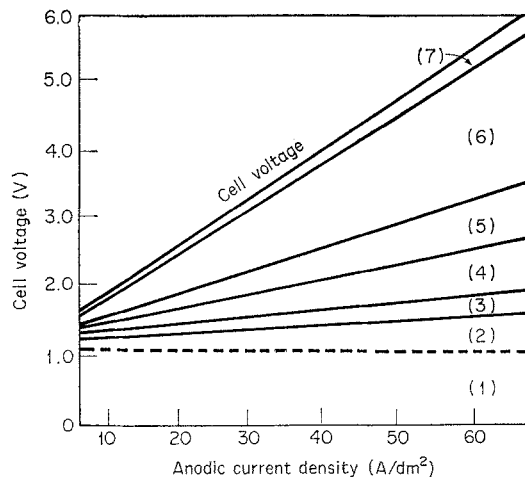

Fig. 4. Voltage balance under operations (450°C). 1: theoretical decomposition voltage; 2: total overvoltage; 3: ohmic loss at anode part; 4: ohmic loss at cathode part; 5: ohmic loss at anode holder; 6: ohmic loss at cathode holder; 7: ohmic loss at bulk electrolyte.

CuCl<sub>2</sub>-NaCl, are not suitable. AlCl<sub>3</sub>-NaCl has a very high vapour pressure and attacks the electrode, and therefore it is also unsuitable. CaCl<sub>2</sub>-NaCl, KCl-ZnCl<sub>2</sub>, NaCl-KCl-ZnCl<sub>2</sub> are all easy to handle and are suitable for our purpose.

In the case of the electrolyte which contains zinc ion, the successive reaction seems to occur; i.e. deposition of zinc and its reaction with hydrogen chloride. In that case, a temperature in excess of 400°C seems necessary for the direct reduction of the hydrogen chloride gas to occur.

### Behaviour of the anode and cathode

Current-voltage characteristics of the anode and cathode are shown in Figs. 5 and 6 respectively. Ohmic loss is measured by the current interruption method. From these figures, it is evidently more important to try to decrease the cathodic overvoltage. Of course, it is also important to try to decrease the ohmic-drop.

### Effect of the catalyst

In order to decrease the cathodic overvoltage, a little amount of palladium chloride is added to the electrolyte; its concentration is about 0.04 wt%. Figs. 7 and 8 show the effect of this.

The current-voltage characteristics of the

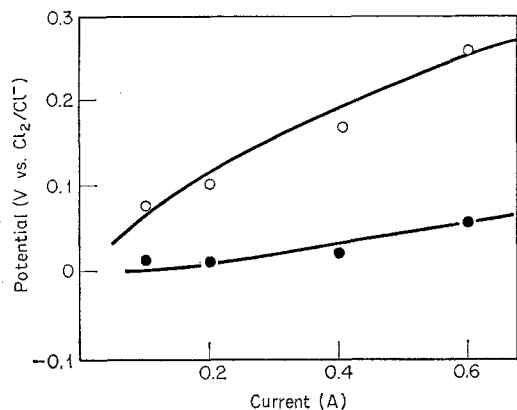

Fig. 5. Potential-current characteristics of  $\text{Cl}_2$  electrode. Apparent surface area  $1.5 \text{ cm}^2$ .  $\circ$ : observed values;  $\bullet$ : values after ohmic drops are corrected for.

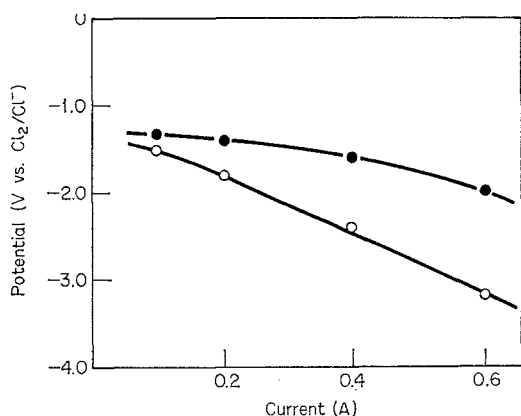

Fig. 6. Potential-current characteristics of  $\text{HCl}$  electrode. Apparent surface area  $1.5 \text{ cm}^2$ .  $\circ$ : observed values;  $\bullet$ : values after ohmic drops are corrected for.

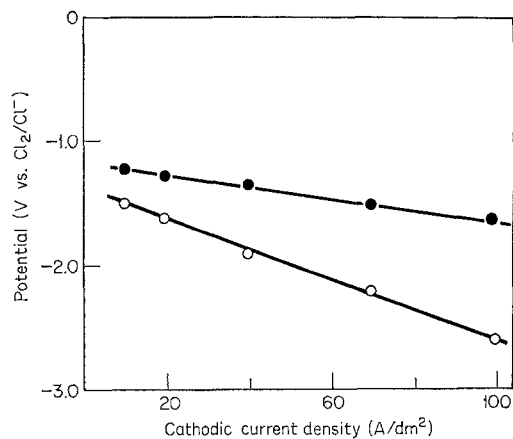

Fig. 7. Cathodic polarization characteristics ( $450^\circ\text{C}$ ).  $\circ$ : in pure electrolyte;  $\bullet$ : when  $\text{PdCl}_2$  is added (ohmic losses are corrected for).

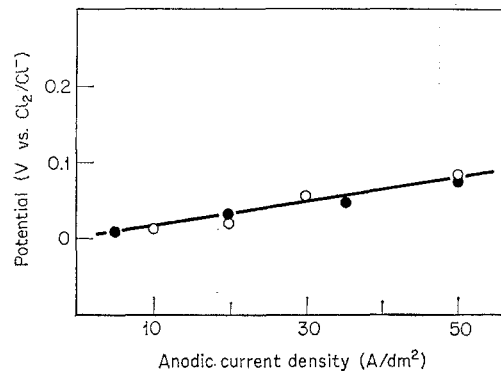

Fig. 8. Anodic polarization characteristics ( $450^\circ\text{C}$ ).  $\circ$ : pure electrolyte;  $\bullet$ : when  $\text{PdCl}_2$  is added (provided there are no ohmic losses).

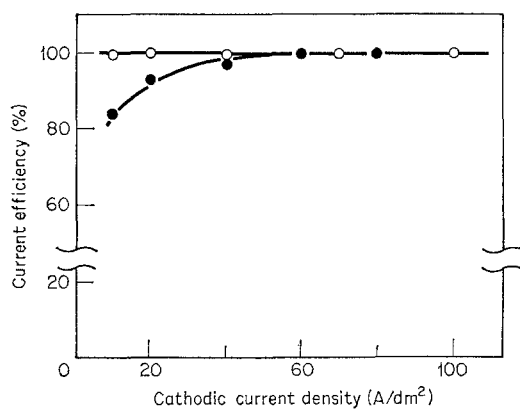

Fig. 9. Current efficiency for  $\text{H}_2$  evolution ( $450^\circ\text{C}$ ).  $\circ$ : pure electrolyte;  $\bullet$ : when  $\text{PdCl}_2$  is added.

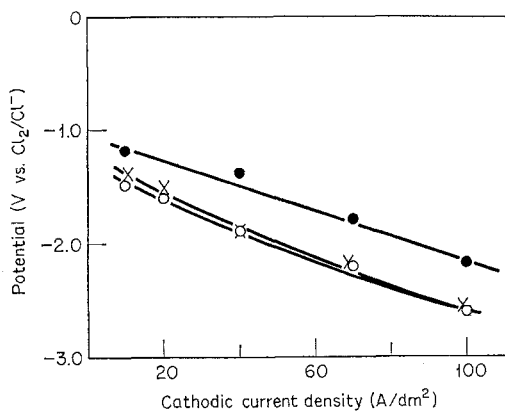

Fig. 10. The effect of  $\text{Pd}$  and  $\text{Ag}$  catalysts on the cathodic polarization characteristics.  $\bullet$ :  $\text{Pd}$  impregnated porous carbon electrode;  $\times$ :  $\text{Ag}$  impregnated porous carbon electrode;  $\circ$ : porous carbon electrode without catalyst (provided there are no ohmic losses).

cathode are largely improved. The current efficiency is not disturbed when the cathodic current density is more than 60 A/dm<sup>2</sup>, as shown in Fig. 9.

A similar catalytic effect is observed when some noble metals are placed on the carbon cathode, as shown in Fig. 10.

The mechanisms of these catalytic phenomena

seems to be the same; that is, in both cases the metal deposited on the carbon cathode acts as a catalyst. It therefore seems more effective and economic to add them in advance.

**Bench scale tests**

Bench scale tests were also carried out. The apparatus is shown in Fig. 11. The cell capacity is about 20 A. The anode is graphite and the cathode is porous carbon as already described in the preceding section. The details of the anode

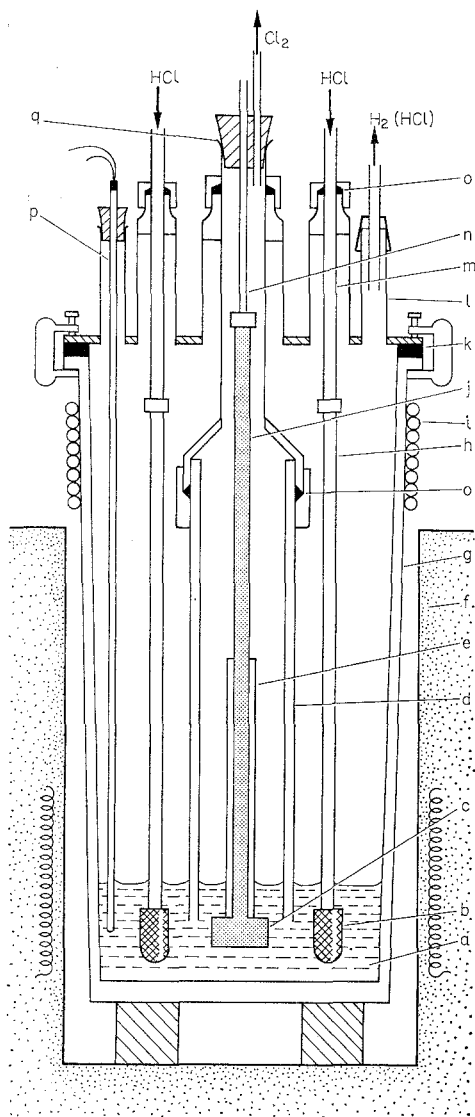

Fig. 11. Electrolytic cell (cell capacity 20 A). a: electrolyte (LiCl—KCl); b: cathode (porous carbon); c: anode (graphite) d: skirt; e: anode lead protector; f: electric furnace; g: cell (porcelain); h: cathode lead (carbon); i: cooling tube; j: anode lead (graphite); k: teflon packing; l: stainless steel cap (SUS 27); m: cathode lead (stainless steel); n: anode lead (stainless steel); o: asbestos packing; p: thermocouple; q: silicon rubber.

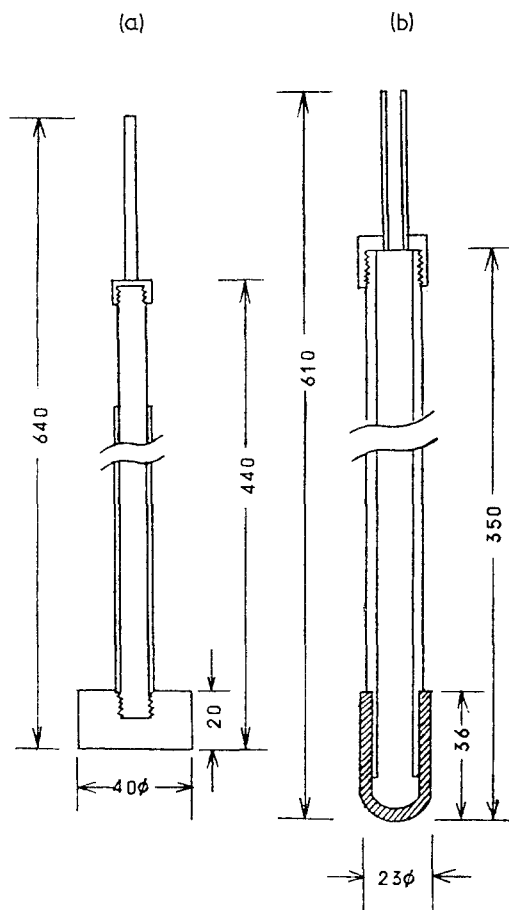

Fig. 12. Construction of the electrodes (unit; mm). (a) anode; (b) cathode.

and cathode are shown in Fig. 12. One anode is surrounded by 6 cathodes. The voltage balance of this cell is shown in Fig. 13 and the relation between working temperature and cell voltage is shown in Fig. 14.

The theoretical decomposition voltage of hydrogen chloride decreases slightly as the working temperature rises; for example, it is

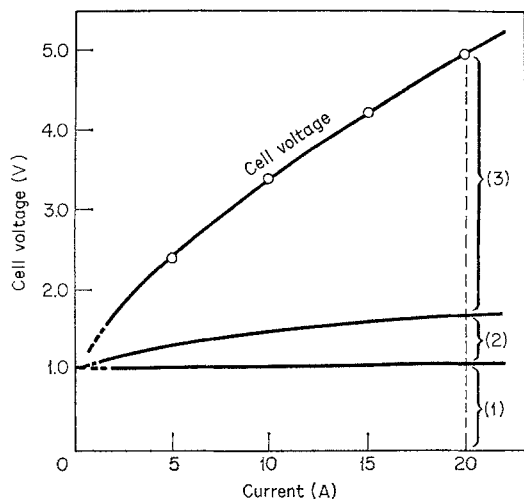

Fig. 13. Voltage balance (500°C, electrode distance 3.8 cm). (1) theoretical decomposition voltage; (2) total overvoltage; (3) ohmic loss.

about 1.01 V at 40°C and 1.04 V at 600°C. On the other hand, the conductivity of the electrolyte increases markedly as the working temperature

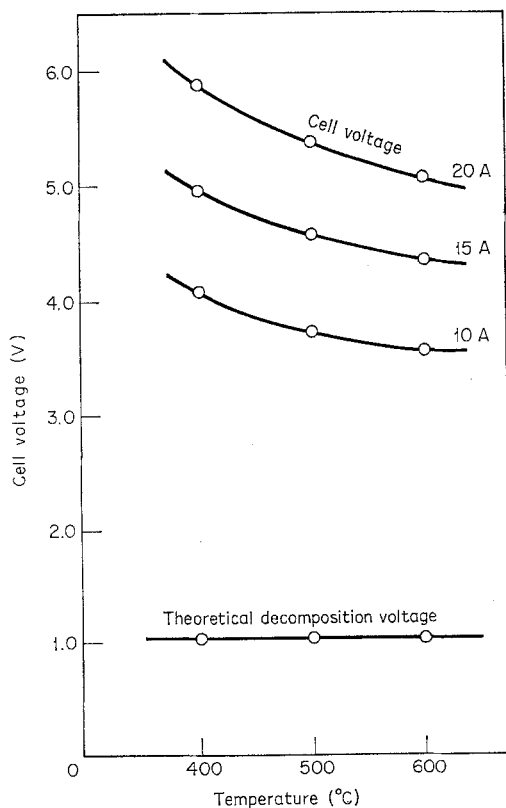

Fig. 14. Relationship between cell voltage and temperature.

rises. So, from the point of view of the electrolytic energy consumption, the higher temperature is preferable. But, at the same time, the technical problems such as material corrosion and difficulties of handling must be taken into account. So it seems most suitable to work at about 400°C or 500°C. Fig. 15 shows the current efficiencies. Both anodic and cathodic current efficiencies are more than 90%. Conversion efficiency from hydrogen chloride to hydrogen is shown in Table 3. The efficiency is rather low, especially

Table 3. Conversion efficiency of the hydrogen chloride

Current (A)	Conversion efficiency (%)
10	5.6
15	8.2
20	11.0

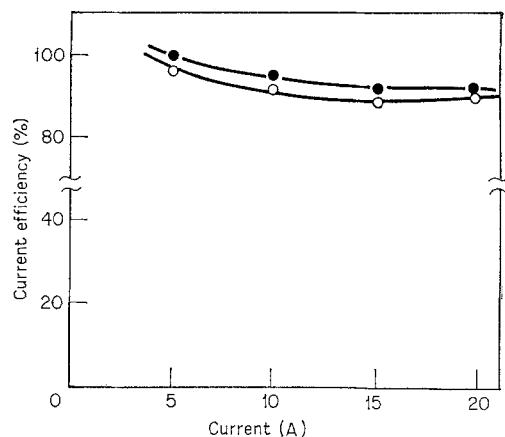

Fig. 15. Current efficiencies (500°C, electrode distance 3.8 cm). ●: hydrogen evolution efficiency; ○: chlorine evolution efficiency.

in the low current density range. But this efficiency can surely be improved to much higher values by decreasing the hydrogen chloride gas supply rate, using denser porous carbon cathodes and arranging the electrodes as shown in Fig. 16.

### Conclusion

A new method has been developed for the recovery of chlorine from by-product hydrogen chloride. Hydrogen chloride gas is led through a carbon pipe to a gas diffusion-type porous carbon cathode, which is immersed in a molten salt of lithium chloride (58 mol%)–potassium

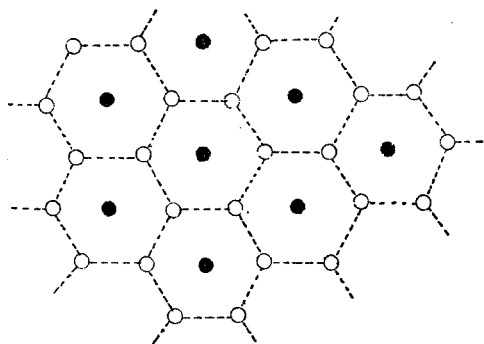

Fig. 16. Possible arrangement of the electrodes. ●: anode; ○: cathode.

chloride (42 mol%) at 400°C. The graphite anode is immersed in the same electrolyte.

By the direct electrolysis of gaseous hydrogen chloride, hydrogen is obtained from the cathode and chlorine is obtained from the anode.

The cell voltage (provided there are no ohmic losses) is 2.3 V at 200 A/dm<sup>2</sup> and current efficiency is more than 90%.

The possibility of using other electrolytes was examined and CaCl<sub>2</sub>-NaCl, KCl-ZnCl<sub>2</sub> and NaCl-KCl-ZnCl<sub>2</sub> systems are also found to be suitable for a long term electrolysis.

Palladium shows a catalytic activity for the cathodic reaction. Bench scale tests were also

carried out. The current capacity is 20 A. The cell voltage is 4.9 V at 20 A (500°C, electrode distance 3.8 cm) and in this case more than 65% of it is the ohmic loss. The current efficiency is more than 90% and the conversion efficiency of hydrogen chloride gas to hydrogen gas is 11.0% at 20 A.

As indicated from the data mentioned above, this method seems promising.

#### Acknowledgments

The authors gratefully acknowledge indispensable aid from Kanto Denka Kogyo Co. Ltd., Japan.

#### References

- [1] H. Deacon, U.S. Patent 85370 (1868).
- [2] H. G. Janson, *Chem. Ing. Tech.*, **39**, (1967) 729.
- [3] P. Gallone and G. Hessner, *Electrochem. Technol.*, **3** (1965) 321.
- [4] F. S. Low, U.S. Patent 2,468,766 (1949).
- [5] D. W. Schröder, *Ind. Eng. Chem., Progress Design Development*, **1**, (1962) 141.
- [6] W. Teske and Hülmanni, *Z. Elektrochem.*, **66** (1962) 787.
- [7] F. Hine, S. Yoshizawa, K. Yamakawa and Y. Nakane, *Electrochemical Technology*, **4** (1966) 555.
- [8] A. G. Oblad, *Ind. Eng. Chem.*, **61** (1969) 23.